

*livin' in a new light*



STRADALI GALLERIE PENSILINE CAPANNONI  
STREETLIGHTS TUNNELS CANOPIES HIGH BAY

# Legenda

**CE** Rispetta i requisiti previsti delle Direttive Comunitarie Europee.  
*In compliance with the European Community Directives.*

**European Norms Electrical Certification**

**TÜV NRTL** - Rispetta i requisiti previsti dalle normative di qualità e sicurezza Nord Americane.  
*In compliance with the North American quality and safety regulations.*

**ATEX** - Il prodotto rispetta i requisiti della Direttiva 94/9/CE in tema di installazione in ambienti a rischio esplosione.  
*The product meets the 94/9/CE Directive in terms of installation in an ambient at risk of explosion.*

**CLASS I** - Isolamento semplice con la messa a terra.  
*Simple insulation with connection to electrical earth.*

**CLASS II** - Isolamento doppio, non devono avere la connessione di messa a terra né la lampada né il palo.  
*Double insulation, it does not require a safety connection to electrical earth.*

**CLASS III** - Alimentazione con trasformatore di sicurezza e bassissima tensione, non necessita di terra di protezione.  
*Very low voltage feeding with security transformer, no earth required.*

**IPX4** - Protetto contro gli spruzzi d'acqua da ogni direzione.  
*Plash-proof from any direction.*

**IPx5** - Protetto dai getti d'acqua. / *Jet-proof.*

**IPx7** - Protetto dalla momentanea sommersione.  
*Suitable for operating occasionally submerged.*

**IP5x** - Protetto contro la polvere. / *Satisfactory operation in dust condition.*

**IP6x** - Totalmente protetto contro la polvere. / *Total dust-proof.*

**Non idoneo per montaggio su superfici normalmente infiammabili.**  
*No suitable for mounting on normally inflammable surfaces.*

**Idoneo per montaggio su superfici normalmente infiammabili.**  
*Suitable for mounting on normally inflammable surfaces.*

**Alimentatore indipendente.** / *Independent power supply.*

**CCT** Temperatura di colore della sorgente utilizzata.  
*Correlated color temperature.*

**CRI** Indice colorimetrico della sorgente utilizzata.  
*Color rendering index.*

**L70** Riduzione di flusso al 70% del flusso iniziale.  
*Lumen depreciation to 70% of initial lumen output.*

Direttiva / Directive **2012/19/UE**

**È obbligatoria la raccolta separata a fine vita dell'apparecchio.**  
*Separate collection is mandatory.*

Direttiva / Directive **2011/95/CE**

**RoHS COMPLIANT** Conforme alla normativa che impone restrizioni sull'uso di determinate sostanze pericolose nella costruzione di vari tipi di apparecchiature elettriche ed elettroniche.  
*In compliance with the norm restricting the use of dangerous materials in electronic components and assemblies.*

# Ottiche / Optics

Le diverse ottiche a nostra disposizione permettono di personalizzare ogni prodotto in funzione delle esigenze progettuali.

*These several proprietary optics are our competitive advantage for product customization according to the project requirements.*

<b>1A</b> 	Stradale Roads	<b>13S</b> 	Pensiline Passaggi pedonali Canopies Crosswalks
<b>3S</b> 	Parcheggi Pensiline Arredo urbano Parking lots Canopies Urban design	<b>15S</b> 	Parcheggi Pensiline Arredo urbano Parking lots Canopies Urban design
<b>5A</b> 	Gallerie Tunnels	<b>16A 2 DX</b> 	Passaggi pedonali Crosswalks
<b>6A</b> 	Parcheggi Parking lots Area	<b>16A 2 SX</b> 	Passaggi pedonali Crosswalks
<b>8A</b> 	Ciclopedonale Svincoli Stradale Cycle/Pedestrian Junctions/Ramps Roads	<b>18A</b> 	Stradale Roads
<b>14A</b> 	Stradale Roads	<b>20S</b> 	Industriali Industrial

For more information please visit

**www.dleds.com**

Per maggiori informazioni consultate il nostro sito

**www.dleds.com**



**DETAS SpA** - Dleds division  
Via Treponti, 29 - 25086 Rezzato (BS) ITALY  
Tel. +39 030 2594120 - Fax +39 030 2792864  
**www.dleds.com** - info@dleds.com

An ISO 9001:2008 certified company  
RAEE IT80200000001378  
Con riserva di modifiche S.E.&O. / Subject to change E.&O.E.



Pag. 04 - Glow



Pag. 06 - Mini City



Pag. 08 - Mizar



Pag. 10 - Convoy



Pag. 12 - Quincy



Pag. 14 - Mini Quincy

## Arredo urbano Urban design



Pag. 16 - Stratos N



Pag. 18 - Stratos P/G



Pag. 20 - Akron



Pag. 22 - Maya 2/3



Pag. 24 - WPA

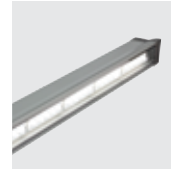

Pag. 26 - Trilogy N

## Stradali Streetlights



Pag. 28 - Radiant 4



Pag. 30 - Radiant 2



Pag. 32 - Radiant 5

## Gallerie Tunnels



Pag. 34 - Atlas PE



Pag. 36 - Atlas 14



Pag. 46 - Trilogy Bust



Pag. 44 - Gong/Zak

## Pensiline Canopy lights



Pag. 38 - Kesu



Pag. 40 - Janus



Pag. 42 - Pad



Pag. 30 - Radiant 2



Pag. 32 - Radiant 5



Pag. 26 - Trilogy N

## Industriali Industrial / High bay

# Glow

Modelli / Models					
nr. LED	Type	Power [W]	nr. LED	Type	Power [W]
1	V	13	1	V	26

## Ottiche disponibili / Available optics

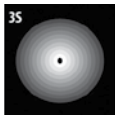

**Corpo illuminante a LED utilizzato per parchi, giardini, zone periferiche, ideale per installazioni a muro.**

Contenitore in alluminio pressofuso  
Vetro temprato 4 mm  
L70 >70.000 ore  
Protezione IP65  
230 VAC Classe II  
Peso 5,2kg  
Disponibile 3000K, 4100K, 5500K

**LED light suitable for parks, gardens, suburban areas, perfect for wall installation.**

*Aluminum die cast body  
Tempered glass 4 mm  
L70 >70.000 hrs  
IP65 protection  
230 VAC Class II  
Weight 5,2kg  
Available 3000K, 4100K, 5500K*

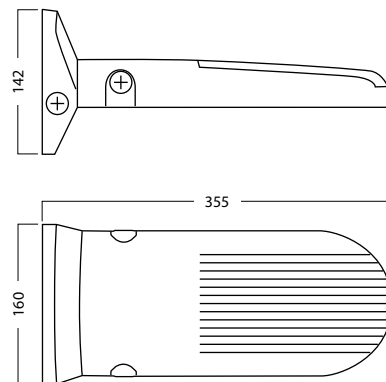

**DETAS SpA** - Dleds division  
Via Treponti, 29 - 25086 Rezzato (BS) ITALY  
Tel. +39 030 2594120 - Fax +39 030 2792864  
[www.dleds.com](http://www.dleds.com) - [info@dleds.com](mailto:info@dleds.com)

An ISO 9001:2008 certified company  
RAEE IT80200000001378  
Con riserva di modifiche S.E.&O. / Subject to change E.&O.E.

# Glow

Corpo illuminante a LED da parete  
*Wall-mount LED luminaire*

**230 VAC**



# Mini City

Modelli / Models											
nr. LED	Type	Current [mA]	Power [W]	nr. LED	Type	Current [mA]	Power [W]	nr. LED	Type	Current [mA]	Power [W]
10	R	550	<b>18</b>	20	R	350	<b>22</b>	30	R	350	<b>34</b>
10	R	700	<b>23</b>	20	R	550	<b>35</b>	30	R	550	<b>53</b>
				20	R	700	<b>44</b>	30	R	700	<b>65</b>

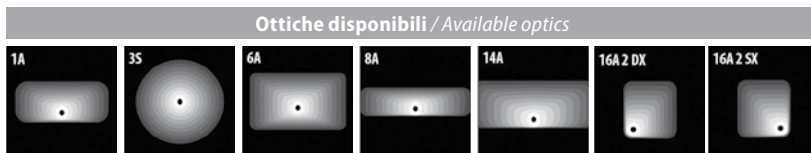

**Progettato per rinnovare economicamente l'impatto estetico di diversi contesti urbani avvalendosi dell'aggiornamento tecnologico a LED. Le diverse ottiche disponibili lo rendono adatto a parchi, aree pubbliche, strade e piste ciclabili.**

Contenitore in alluminio pressofuso  
 Vetro temprato 5 mm  
 L70 >100.000 ore  
 Protezione IP65  
 230 VAC Classe II  
 Peso 6.5 kg  
 Montaggio su palo  $\varnothing$  48 mm  
 Disponibile 3000K, 4100K, 5500K

**Cost effective LED light ideal for retrofitting existing obsolete units.  
 High performing optics suitable for parks, cycle lanes and public areas.**

Aluminum die cast body  
 Tempered glass 5 mm  
 L70 >100.000 hrs  
 IP65 protection  
 230 VAC Class II  
 Weight 6.5 kg  
 Pole mounting  $\varnothing$  48 mm

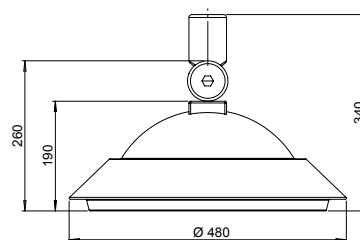

**DETAS SpA** - Dleds division  
 Via Treponti, 29 - 25086 Rezzato (BS) ITALY  
 Tel. +39 030 2594120 - Fax +39 030 2792864  
**www.dleds.com** - info@dleds.com

An ISO 9001:2008 certified company  
 RAEE IT80200000001378  
 Con riserva di modifiche S.E.&O. / Subject to change E.&O.E.

# Mini City

Corpo illuminante a LED  
*LED luminaire*

**230 VAC**



# Mizar

Modelli / Models											
nr. LED	Type	Current [mA]	Power [W]	nr. LED	Type	Current [mA]	Power [W]	nr. LED	Type	Current [mA]	Power [W]
10	R	550	<b>18</b>	20	R	350	<b>22</b>	30	R	350	<b>34</b>
10	R	700	<b>23</b>	20	R	550	<b>35</b>	30	R	550	<b>53</b>
				20	R	700	<b>44</b>	30	R	700	<b>65</b>

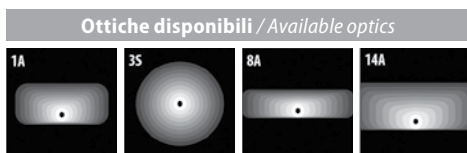

**Disegno elegante, linee pulite ed ottiche performanti: ideale per parchi, piazzali e piste ciclabili.**

Corpo in alluminio pressofuso  
Vetro temprato 5 mm  
L70 >100.000 ore  
Protezione IP65  
230 VAC Classe II  
Peso 14 kg  
Disponibile 3000K, 4100K, 5500K

**Elegant design with high performing optics: suitable for parks, cycle lanes and public areas.**

Aluminum die cast body  
Tempered glass 5 mm  
L70 >100.000 hrs  
IP65 protection  
230 VAC Class II  
Weight 14 kg  
Available 3000K, 4100K, 5500K

**Dimmer e controllo remoto wireless su richiesta.**

*Dimming and remote wireless control on request.*

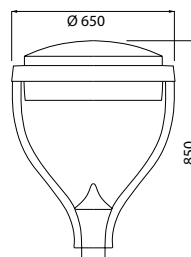

**DETAS SpA** - Dleds division  
Via Treponti, 29 - 25086 Rezzato (BS) ITALY  
Tel. +39 030 2594120 - Fax +39 030 2792864  
[www.dleds.com](http://www.dleds.com) - [info@dleds.com](mailto:info@dleds.com)

An ISO 9001:2008 certified company  
RAEE IT80200000001378  
Con riserva di modifiche S.E.&O. / Subject to change E.&O.E.



# Mizar

Corpo illuminante a LED  
*LED luminaire*

**230 VAC**



# Convoy

Modelli / Models											
nr. LED	Type	Current [mA]	Power [W]	nr. LED	Type	Current [mA]	Power [W]	nr. LED	Type	Current [mA]	Power [W]
			<b>18</b>	20	R	350	<b>22</b>	30	R	350	<b>34</b>
10	R	550		20	R	550	<b>35</b>	30	R	550	<b>53</b>
10	R	700	<b>23</b>	20	R	700	<b>44</b>	30	R	700	<b>65</b>

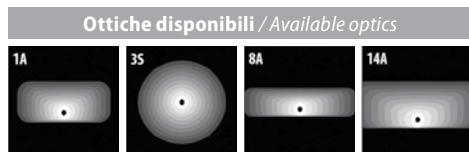

**Disegno elegante, linee pulite ed ottiche performanti: ideale per parchi, piazzali e piste ciclabili.**

Contenitore in alluminio pressofuso  
 Vetro temprato 5 mm  
 L70 >100.000 ore  
 Protezione IP65  
 230 VAC Classe II/I  
 Peso 8 kg  
 Disponibile 3000K, 4100K, 5500K

**Elegant design and highly performing optics: suitable for parks, cycle lanes and public areas.**

*Aluminum die cast body  
 Tempered glass 5 mm  
 L70 >100.000 hrs  
 IP65 protection  
 230 VAC Class II/I  
 Weight 8 kg  
 Available 3000K, 4100K, 5500K*

**Dimmeraggio e controllo remoto wireless su richiesta.**

*Dimming and remote wireless control on request.*

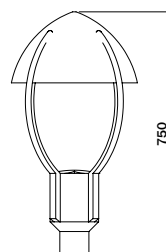
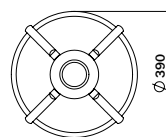

**DETAS SpA** - Dleds division  
 Via Treponti, 29 - 25086 Rezzato (BS) ITALY  
 Tel. +39 030 2594120 - Fax +39 030 2792864  
**www.dleds.com** - info@dleds.com

An ISO 9001:2008 certified company  
 RAEE IT8020000001378  
 Con riserva di modifiche S.E.&O. / Subject to change E.&O.E.



# Convoy

Corpo illuminante a LED  
*LED street light*

**230 VAC**



# Quincy

Modelli / Models											
nr. LED	Type	Current [mA]	Power [W]	nr. LED	Type	Current [mA]	Power [W]	nr. LED	Type	Current [mA]	Power [W]
10	R	550	<b>18</b>	20	R	350	<b>22</b>	30	R	350	<b>34</b>
10	R	700	<b>23</b>	20	R	550	<b>35</b>	30	R	550	<b>53</b>
10	R	700	<b>23</b>	20	R	700	<b>44</b>	30	R	700	<b>65</b>

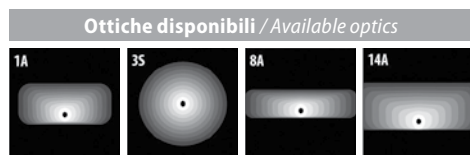

**Classico e tradizionale corpo di illuminazione per l'arredo urbano, aggiornato con tecnologia LED.**

Corpo in alluminio pressofuso  
Vetro temprato 4 mm  
L70 >100.000 ore  
Protezione IP65  
230 VAC Classe II  
Peso 8 kg  
Disponibile 3000K, 4100K, 5500K

**Classic and traditional design luminaire for street furnishing, updated with LED technology**

Aluminum die cast body  
Tempered glass 4 mm  
L70 >100.000 hrs  
IP65 protection  
230 VAC Class II  
Weight 8 kg  
Available 3000K, 4100K, 5500K

**Dimmer e controllo remoto wireless su richiesta.**

*Dimming and remote wireless control on request.*

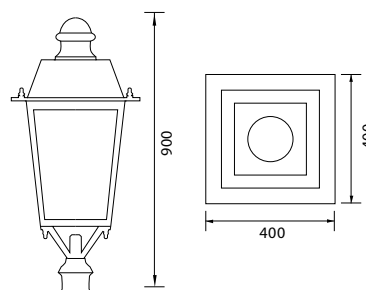

**DETAS SpA** - Dleds division  
Via Treponti, 29 - 25086 Rezzato (BS) ITALY  
Tel. +39 030 2594120 - Fax +39 030 2792864  
[www.dleds.com](http://www.dleds.com) - [info@dleds.com](mailto:info@dleds.com)

An ISO 9001:2008 certified company  
RAEE IT80200000001378  
Con riserva di modifiche S.E.&O. / Subject to change E.&O.E.



# Quincy

Corpo illuminante a LED  
*LED luminaire*

**230 VAC**



# Mini Quincy

Modelli / Models	
Type	Power [W]
MQ-OP-1AN	<b>13</b>
MQ-OP-2AN	<b>26</b>

## Ottiche disponibili / Available optics

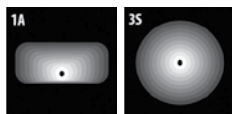

**Classico e tradizionale corpo di illuminazione per l'arredo urbano, aggiornato con tecnologia LED.**

Corpo in alluminio pressofuso  
 Vetro temperato 4 mm  
 L70 >50.000 ore  
 Protezione IP65  
 230 VAC Classe I  
 Peso 4 kg  
 Disponibile 3000K, 4100K, 5500K

***An urban designed classical solution retrofitted with LED technology.***

*Aluminum die cast body  
 Tempered glass 4 mm  
 L70 >50.000 hrs  
 IP65 protection  
 230 VAC Class I  
 Weight 4 kg  
 Available 3000K, 4100K, 5500K*

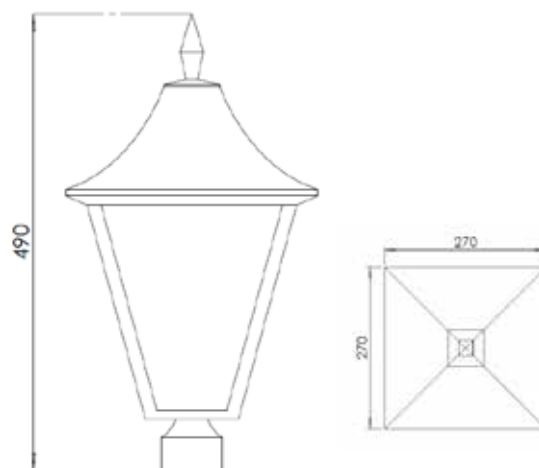

**DETAS SpA** - Dleds division  
 Via Treponti, 29 - 25086 Rezzato (BS) ITALY  
 Tel. +39 030 2594120 - Fax +39 030 2792864  
**www.dleds.com** - info@dleds.com

An ISO 9001:2008 certified company  
 RAEE IT80200000001378  
 Con riserva di modifiche S.E.&O. / Subject to change E.&O.E.



# Mini Quincy

Corpo illuminante a LED  
*LED street light*

**230 VAC**



# Stratos N

Modelli / Models											
nr. LED	Type	Current [mA]	Power [W]	nr. LED	Type	Current [mA]	Power [W]	nr. LED	Type	Current [mA]	Power [W]
5	R	700	<b>12</b>	15	R	550	<b>26</b>	20	R	700	<b>44</b>
10	R	550	<b>18</b>	15	R	700	<b>33</b>	25	R	550	<b>44</b>
10	R	700	<b>23</b>	20	R	550	<b>35</b>	25	R	700	<b>55</b>

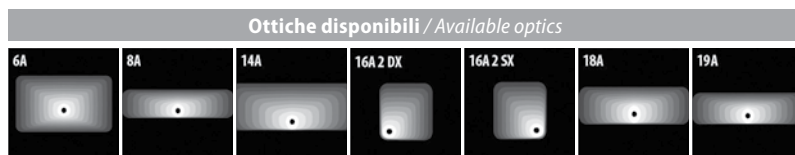

**Corpo illuminante a LED compatto, di piacevole design e di imbattibile rapporto prezzo/prestazioni. Grazie alle molteplici ottiche disponibili può essere utilizzato per strade, parcheggi, attraversamenti pedonali e ciclopedonali.**

Registered Community Design  
 Contenitore in alluminio pressofuso SUPERCAS<sup>®</sup>  
 Vetro temprato 5 mm  
 L70 >100.000 ore  
 Protezione IP66  
 230 VAC Classe II  
 Disponibile Classe I  
 Peso 5.5 kg  
 Disponibile 3000K, 4100K, 5500K

**Compact LED luminaire, with excellent price/performance ratio. Thanks to the several optics available, it can be used for streets, parking lots, pedestrian crossings and cycle lanes.**

Registered Community Design  
 SUPERCAS<sup>®</sup> Aluminum die cast body  
 Tempered glass 5 mm  
 L70 >100.000 hrs  
 IP66 protection  
 230 VAC Class II/I  
 Weight 5.5 kg  
 Available 3000K, 4100K, 5500K

**Dimmeraggio e controllo remoto wireless su richiesta.**  
 Dimming and remote wireless control on request.

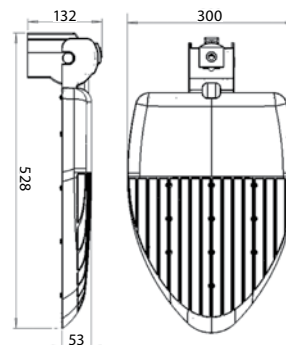

SUPERCAS<sup>®</sup> A360



Lega di alluminio esente da corrosione  
 Corrosion Free Aluminum Alloy



**DETAS SpA** - Dleds division  
 Via Treponti, 29 - 25086 Rezzato (BS) ITALY  
 Tel. +39 030 2594120 - Fax +39 030 2792864  
**www.dleds.com** - info@dleds.com

An ISO 9001:2008 certified company  
 RAEE IT8020000001378  
 Con riserva di modifiche S.E.&O. / Subject to change E.&O.E.



# Stratos N

Corpo illuminante a LED  
*LED street light*

**230 VAC**  
**12 VDC fotovoltaic**

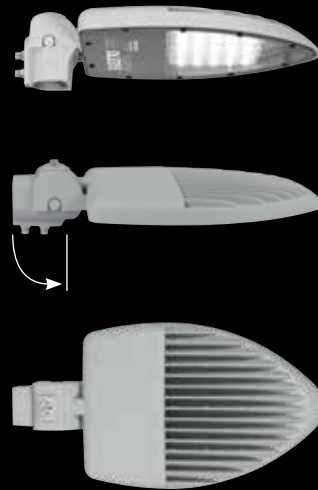
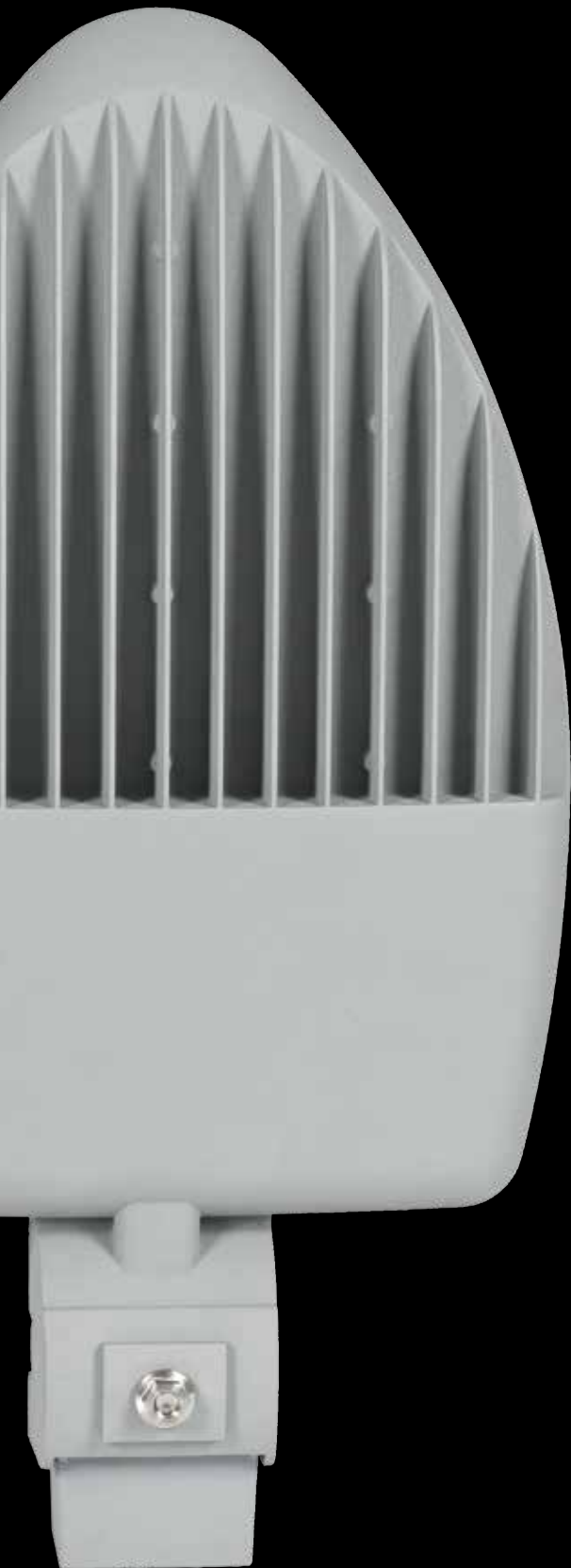

# Stratos P/G

Modelli / Models											
nr. LED	Type	Current [mA]	Power [W]	nr. LED	Type	Current [mA]	Power [W]	nr. LED	Type	Current [mA]	Power [W]
<b>STRATOS P</b>											
30	R	550	<b>53</b>	40	R	550	<b>68</b>	50	R	550	<b>84</b>
30	R	700	<b>65</b>	40	R	700	<b>85</b>	50	R	700	<b>105</b>
<b>STRATOS G</b>											
60	R	550	<b>100</b>	70	R	550	<b>124</b>	80	R	550	<b>135</b>
60	R	700	<b>125</b>	70	R	700	<b>154</b>	80	R	700	<b>175</b>

Ottiche disponibili / Available optics						
6A	8A	14A	16A 2 DX	16A 2 SX	18A	19A

SUPERCAST® A360



Lega di alluminio esente da corrosione  
Corrosion Free Aluminum Alloy



**Corpo illuminante a LED per strade, parcheggi, rotatorie e svincoli in rispondenza alle norme di settore. Con 7 differenti soluzioni ottiche il risparmio energetico è massimizzato.**

Registered Community Design  
 Contenitore in alluminio pressofuso SUPERCAS<sup>®</sup>  
 Vetro temprato 5 mm  
 L70 >50.000/100.000 ore  
 Protezione IP66  
 230 VAC Classe II  
 Disponibile Classe I  
 Peso 10 kg / 16 kg  
 Disponibile 3000K, 4100K, 5500K

**LED streetlight cobrahead with very low and attractive design. It is mainly used for streetlighting but it can be installed for area and parking lots as well. With 7 different optical solutions the energy saving is maximized.**

Registered Community Design  
 SUPERCAS<sup>®</sup> Aluminum die cast body  
 Tempered glass 5 mm  
 L70 >50.000/100.000 hrs  
 IP66 protection  
 230 VAC Class II  
 Available Class I  
 Weight 10 kg / 16 kg  
 Available 3000K, 4100K, 5500K

**Dimmeraggio e controllo remoto wireless su richiesta.**

*Dimming and remote wireless control on request.*

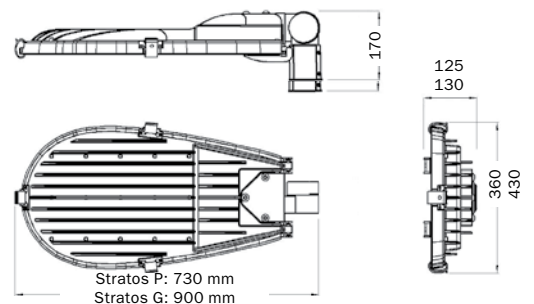

**DETAS SpA** - Dleds division  
 Via Treponti, 29 - 25086 Rezzato (BS) ITALY  
 Tel. +39 030 2594120 - Fax +39 030 2792864  
**www.dleds.com** - info@dleds.com

An ISO 9001:2008 certified company  
 RAEE IT80200000001378  
 Con riserva di modifiche S.E.&O. / Subject to change E.&O.E.



# Stratos P/G

Corpo illuminante a LED  
*LED street light*

**230 VAC**



# Akron

Modelli / Models							
nr. LED	Type	Current [mA]	Power [W]	nr. LED	Type	Current [mA]	Power [W]
25	R	550	<b>44</b>	30	R	550	<b>53</b>
25	R	700	<b>55</b>	30	R	700	<b>65</b>
40	R	550	<b>68</b>	50	R	550	<b>84</b>
40	R	700	<b>85</b>	50	R	700	<b>105</b>

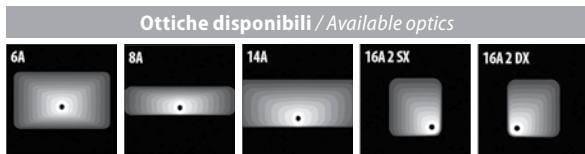

**Illuminazione funzionale per aree esterne, commerciali ed industriali. Grazie alle ottiche disponibili può essere usato per strade, parcheggi ed attraversamenti pedonali.**

Corpo in alluminio pressofuso  
 Vetro temprato 5 mm  
 L70 >100.000 ore  
 Protezione IP65  
 230 VAC Classe II/I  
 Peso 8.6 kg  
 Disponibile 3000K, 4100K, 5500K

**Functional lighting for outdoor, commercial and industrial areas. Thanks to the different available optics it can be used also for streets, parking lots and pedestrian crossings.**

Aluminum die cast body  
 Tempered glass 5 mm  
 L70 >100.000 hrs  
 IP65 protection  
 230 VAC Class II  
 Available Class I  
 Weight 8.6 kg  
 Available 3000K, 4100K, 5500K

**Dimmer e controllo remoto wireless su richiesta.**

*Dimming and remote wireless control on request.*

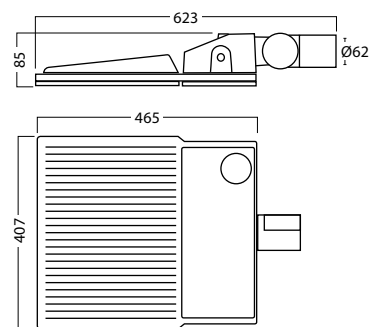

**DETAS SpA** - Dleds division  
 Via Treponti, 29 - 25086 Rezzato (BS) ITALY  
 Tel. +39 030 2594120 - Fax +39 030 2792864  
**www.dleds.com** - info@dleds.com

An ISO 9001:2008 certified company  
 RAEE IT80200000001378  
 Con riserva di modifiche S.E.&O. / Subject to change E.&O.E.

# Akron

Corpo illuminante a LED  
*LED street light*

**230 VAC**



# Maya 2-3

Modelli / Models											
nr. LED	Type	Current [mA]	Power [W]	nr. LED	Type	Current [mA]	Power [W]	nr. LED	Type	Current [mA]	Power [W]
40	R	350	<b>44</b>	50	R	350	<b>55</b>	60	R	350	<b>67</b>
40	R	550	<b>68</b>	50	R	550	<b>84</b>	60	R	550	<b>100</b>
40	R	700	<b>85</b>	50	R	700	<b>105</b>	60	R	700	<b>125</b>

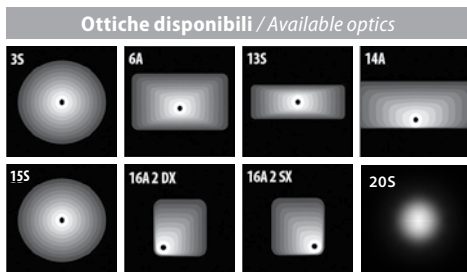

**Progettato per la sicurezza di attraversamenti pedonali, Maya può anche essere utilizzato come armatura stradale, per torrifaro ed altre applicazioni.**

Contenitore in alluminio pressofuso  
 Vetro temprato 4 mm  
 L70 >100.000 ore  
 Protezione IP66  
 230 VAC Classe II  
 Peso 17.5 / 7 kg  
 Disponibile 3000K, 4100K, 5500K

**Designed for improving pedestrian crossings safety, Maya can be also used for streetlighting, light towers and other applications.**

Aluminum die cast body  
 Tempered glass 4 mm  
 L70 >100.000 hrs  
 IP66 protection  
 230 VAC Class II  
 Weight 17.5 / 7 kg

**Dimmer e controllo remoto wireless su richiesta.**

*Dimming and remote wireless control on request.*

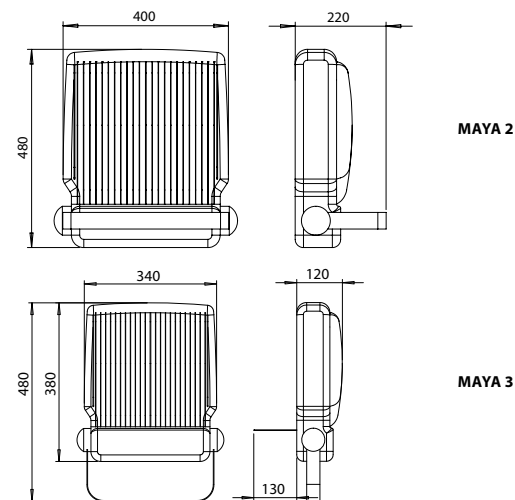

**DETAS SpA** - Dleds division  
 Via Treponti, 29 - 25086 Rezzato (BS) ITALY  
 Tel. +39 030 2594120 - Fax +39 030 2792864  
**www.dleds.com** - info@dleds.com

An ISO 9001:2008 certified company  
 RAEE IT8020000001378  
 Con riserva di modifiche S.E.&O. / Subject to change E.&O.E.

# Maya 2-3

Corpo illuminante a LED per esterni e attraversamenti pedonali  
*Outdoor LED light for general and pedestrian crossing applications*

**230 VAC**



MAYA 2



MAYA 3



# WPA

Modelli / Models					
nr. LED	Type	Power [W]	nr. LED	Type	Power [W]
1	C	35	2	C	50

#### Ottiche disponibili / Available optics

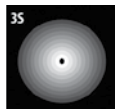

**Proiettore per esterni ideale per illuminare zone adiacenti a capannoni o edifici compresi parcheggi e aree esterne.**

Corpo in alluminio  
L70>70.000 ore  
Protezione IP65  
230VAC Classe I  
Peso: 2,1 Kg  
Disponibile con sensore crepuscolare per on/off automatico  
Disponibile 5000K

**Outdoor lamp, suitable for lighting areas around buildings and small parking lots.**

Aluminum body  
L70 >70.000 hrs  
IP65 protection  
230 VAC Class I  
Weight: 2,1 kg  
Available light sensor for automatic on/off switching  
Available 5000K

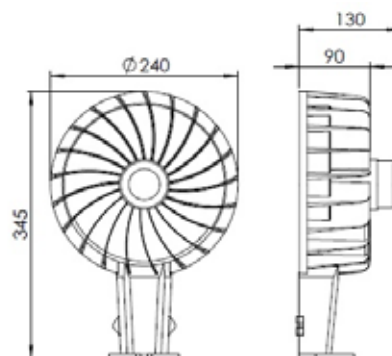

**DETAS SpA** - Dleds division  
Via Treponti, 29 - 25086 Rezzato (BS) ITALY  
Tel. +39 030 2594120 - Fax +39 030 2792864  
[www.dleds.com](http://www.dleds.com) - [info@dleds.com](mailto:info@dleds.com)

An ISO 9001:2008 certified company  
RAEE IT80200000001378  
Con riserva di modifiche S.E.&O. / Subject to change E.&O.E.



# WPA

Corpo illuminante a LED per  
aree esterne  
*LED wall light for outdoor areas*

**230 VAC**



# Trilogy N

Modelli / Models											
nr. LED	Type	Current [mA]	Power [W]	nr. LED	Type	Current [mA]	Power [W]	nr. LED	Type	Current [mA]	Power [W]
5	R	700	<b>12</b>	20	R	550	<b>35</b>	25	R	550	<b>44</b>
15	R	700	<b>33</b>	20	R	700	<b>44</b>	25	R	700	<b>55</b>

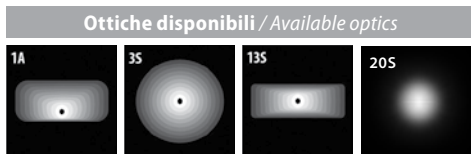

**Barra luminosa a LED utilizzata per illuminazione industriale e di esterni oppure specifica per passaggi pedonali.**

Contenitore in alluminio  
 Vetro temprato 4 mm  
 L70 >100.000 ore  
 Protezione IP66  
 230 VAC Classe II  
 Peso 4.5 kg (100 cm)  
 Disponibile 3000K, 4100K, 5500K  
**Lunghezze disponibili 30; 60; 100 cm**

**LED lightbar typically used for outdoor and industrial lighting or as a light beam for pedestrian crossing.**

Aluminum body  
 Tempered glass 4 mm  
 L70 >100.000 hrs  
 IP66 protection  
 230 VAC Class II  
 Weight 4.5 kg (100 cm)  
 Available 3000K, 4100K, 5500K  
**Lenghts available 30; 60; 100 cm**

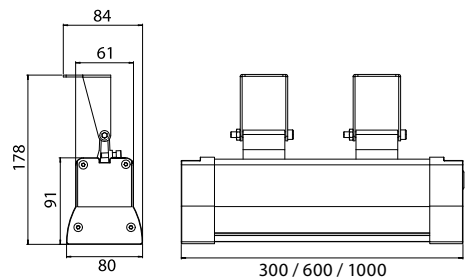

**DETAS SpA** - Dleds division  
 Via Treponti, 29 - 25086 Rezzato (BS) ITALY  
 Tel. +39 030 2594120 - Fax +39 030 2792864  
**www.dleds.com** - info@dleds.com

An ISO 9001:2008 certified company  
 RAEE IT80200000001378  
 Con riserva di modifiche S.E.&O. / Subject to change E.&O.E.

# Trilogy N

Barra LED  
*LED lightbar*

**230 VAC**



# Radiant 4

Modelli / Models			
nr. LED	Type	Current [mA]	Power [W]
40	R	350	<b>45</b>
40	R	530	<b>70</b>

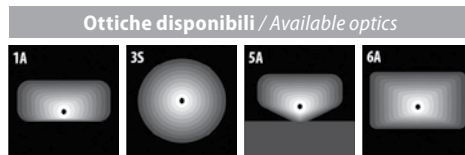

**Soluzione innovativa per l'illuminazione di gallerie: unisce efficacia, efficienza e risparmio energetico.**

Corpo in alluminio pressofuso  
 Vetro temprato 5 mm  
 L70 >90.000 ore  
 Protezione IP65  
 230 VAC Classe II  
 Peso 8.5 kg  
 Disponibile 3000K, 4100K, 5500K

**Cost effective tunnel and outdoor LED light with high performances and extremely long life.**

Aluminum die cast body  
 Tempered glass 5 mm  
 L70 >90.000 hrs  
 IP65 protection  
 230 VAC Class II  
 Weight 8.5 kg  
 Available 3000K, 4100K, 5500K

**Dimmer e controllo remoto su richiesta.**  
 Dimming and remote control on request.

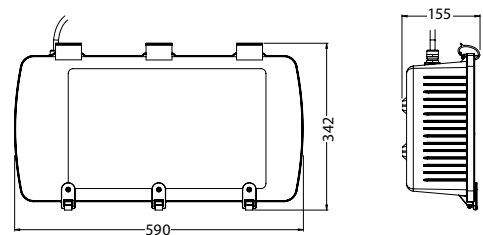

**DETAS SpA** - Dleds division  
 Via Treponti, 29 - 25086 Rezzato (BS) ITALY  
 Tel. +39 030 2594120 - Fax +39 030 2792864  
**www.dleds.com** - info@dleds.com

An ISO 9001:2008 certified company  
 RAEE IT80200000001378  
 Con riserva di modifiche S.E.&O. / Subject to change E.&O.E.

# Radiant 4

Corpo illuminante a LED per gallerie  
*LED luminaire for tunnels*

**230 VAC**



# Radiant 2

Modelli / Models											
nr. LED	Type	Current [mA]	Power [W]	nr. LED	Type	Current [mA]	Power [W]	nr. LED	Type	Current [mA]	Power [W]
26	M	700	<b>215</b>	60	R	350	<b>65</b>				
38	M	700	<b>320</b>	60	R	700	<b>125</b>	102	R	700	<b>220</b>

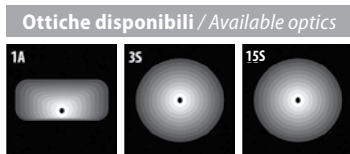

**Soluzione innovativa per l'illuminazione di capannoni e gallerie: unisce efficacia, efficienza e risparmio energetico. Disponibile fino a 320W per ogni necessità.**

Corpo in alluminio pressofuso  
Vetro temprato 5 mm  
L70 >50.000/90.000 ore  
Protezione IP65  
230 VAC Classe II  
Peso 13 kg  
Disponibile 3000K, 4100K, 5500K

**Reliable and heavy duty LED light for tunnels and high bays. Available up to 320W for any application.**

Aluminum die cast body  
Tempered glass 5 mm  
L70 >50.000/90.000 hrs  
IP65 protection  
230 VAC Class II  
Weight 13 kg  
Available 3000K, 4100K, 5500K

**Dimmer e controllo remoto su richiesta.**  
Dimming and remote control on request.

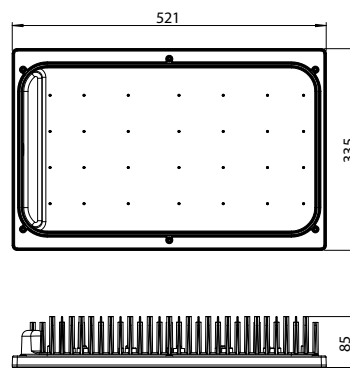

**DETAS SpA** - Dleds division  
Via Treponti, 29 - 25086 Rezzato (BS) ITALY  
Tel. +39 030 2594120 - Fax +39 030 2792864  
[www.dleds.com](http://www.dleds.com) - [info@dleds.com](mailto:info@dleds.com)

An ISO 9001:2008 certified company  
RAEE IT8020000001378  
Con riserva di modifiche S.E.&O. / Subject to change E.&O.E.

# Radiant 2

Corpo illuminante a LED per gallerie e capannoni  
*LED luminaire for tunnels and high bays*

**230 VAC**



# Radiant 5

Modelli / Models											
nr. LED	Type	Current [mA]	Power [W]	nr. LED	Type	Current [mA]	Power [W]	nr. LED	Type	Current [mA]	Power [W]
40	R	700	<b>85</b>	50	R	550	<b>84</b>	60	R	700	<b>125</b>

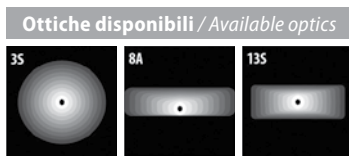

Lega di alluminio esente da corrosione  
Corrosion Free Aluminum Alloy

**Soluzione innovativa per l'illuminazione di capannoni e gallerie: unisce efficacia, efficienza e risparmio energetico. Versione ATEX disponibile.**

Corpo in alluminio pressofuso SUPERCAST®  
Vetro temprato 4 mm  
L70 >70.000 ore  
Protezione IP65  
230 VAC Classe II  
Peso 12 kg  
Disponibile 3000K, 4100K, 5500K

**Reliable and heavy duty LED light for tunnels and high bays. ATEX version available.**

SUPERCAST® Aluminum die cast body  
Tempered glass 4 mm  
L70 >70.000 hrs  
IP65 protection  
230 VAC Class II  
Weight 12 kg  
Available 3000K, 4100K, 5500K

**Dimmer e controllo remoto su richiesta.**  
Dimming and remote control on request.

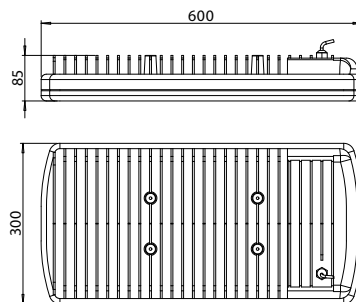

**DETAS SpA** - Dleds division  
Via Treponti, 29 - 25086 Rezzato (BS) ITALY  
Tel. +39 030 2594120 - Fax +39 030 2792864  
[www.dleds.com](http://www.dleds.com) - [info@dleds.com](mailto:info@dleds.com)

An ISO 9001:2008 certified company  
RAEE IT80200000001378  
Con riserva di modifiche S.E.&O. / Subject to change E.&O.E.



# Radiant 5

Corpo illuminante a LED per gallerie e capannoni  
*LED luminaire for tunnels and warehouses*

**230 VAC**

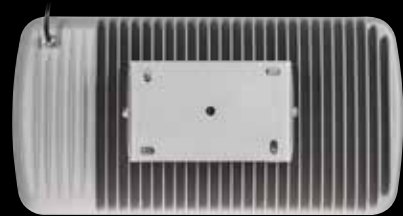
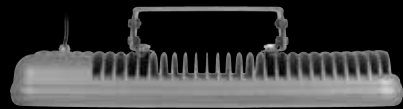

# Atlas PE

Modelli / Models				
	nr. LED	Type	Current [mA]	Power [W]
OP	30	R	530	<b>52</b>
OP	40	R	530	<b>70</b>

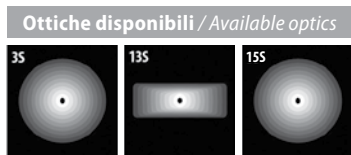

**Corpo da incasso, ideale per illuminare pensiline autostradali e stazioni di servizio. Disponibile versione a plafone. Versione ATEX disponibile.**

Corpo in alluminio  
Vetro temprato 5mm  
L70 >70.000 ore  
Protezione IP55  
230 VAC Classe I o II  
Peso: 4.8 kg  
Disponibile 3000K, 4100K, 5500K

**Recessed light, suitable for motorways and petrol canopies. Surface mount version available. ATEX version available.**

Aluminum body  
L70 >70.000 hrs  
IP55 protection  
230 VAC Class I or II  
Weight: 4.8 kg  
Available 3000K, 4100K, 5500K

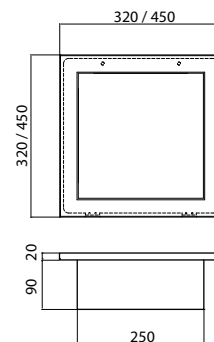

**DETAS SpA** - Dleds division  
Via Treponti, 29 - 25086 Rezzato (BS) ITALY  
Tel. +39 030 2594120 - Fax +39 030 2792864  
[www.dleds.com](http://www.dleds.com) - [info@dleds.com](mailto:info@dleds.com)

An ISO 9001:2008 certified company  
RAEE IT80200000001378  
Con riserva di modifiche S.E.&O. / Subject to change E.&O.E.

# Atlas PE

Corpo illuminanti a LED  
per pensiline  
*Canopies LED light*

**230 VAC**



# Atlas 14

Modelli / Models								
nr. LED	Type	Power [W]	nr. LED	Type	Power [W]	nr. LED	Type	Power [W]
9	C	<b>45</b>	12	C	<b>60</b>	18	C	<b>90</b>
24	C	<b>120</b>	27	C	<b>135</b>			

## Ottiche disponibili / Available optics

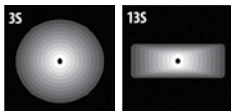

**Corpo illuminante a LED ideale per pensiline.  
Miglior rapporto prezzo/prestazioni.**

Corpo in alluminio  
Dimensioni piastra esterna personalizzabili  
Protezione IP67  
230 VAC Classe I  
Peso 1,9Kg  
Disponibile 3000K, 4100K, 5500K

**Recessed light, suitable for motorways and  
petrol canopies. Best price/performance ratio.**

Aluminum body  
L70 >70.000 hrs  
IP67 protection  
230 VAC Class I  
Weight: 1,9 kg  
Customizable external plate sizes  
Available 3000K, 4100K, 5500K

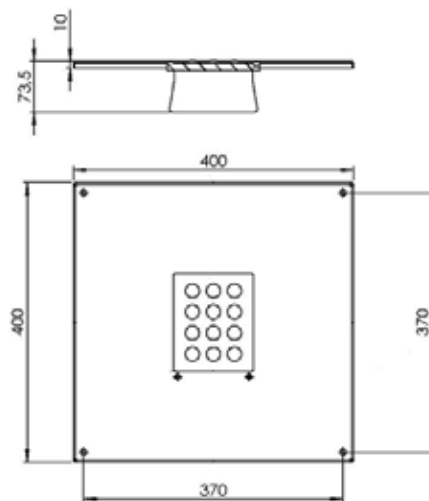

**DETAS SpA** - Dleds division  
Via Treponti, 29 - 25086 Rezzato (BS) ITALY  
Tel. +39 030 2594120 - Fax +39 030 2792864  
[www.dleds.com](http://www.dleds.com) - [info@dleds.com](mailto:info@dleds.com)

An ISO 9001:2008 certified company  
RAEE IT8020000001378  
Con riserva di modifiche S.E.&O. / Subject to change E.&O.E.

# Atlas 14

Corpo illuminanti a LED  
per pensiline  
*Canopies LED light*

**230 VAC**

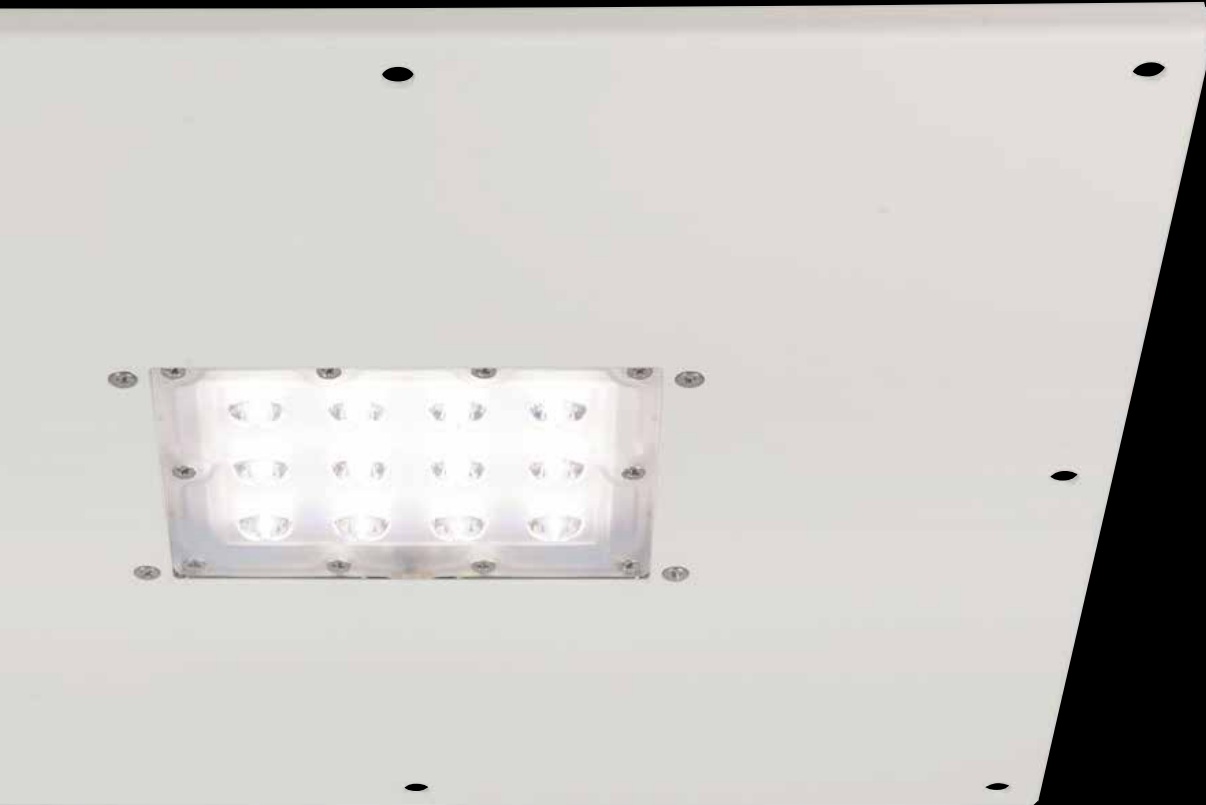

# Kesu

## Modelli / Models

Type	Power [W]
Kesu 120 cm	<b>60</b>

## Ottiche disponibili / Available optics

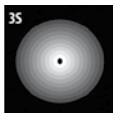

**Plafoniera stagna ideale per la sostituzione di lampade fluorescenti di lunghezza 120 e 150 cm. Perfetta uniformità di illuminamento ed elevata qualità dei materiali utilizzati.**

Custodia in policarbonato  
 L70 > 60.000 ore  
 RA: > 85  
 Protezione IP65  
 230VAC classe II  
 Peso: 2,5 Kg  
 Disponibile 4500K

**Low bay LED watertight light for replacing existing 120 and 150 cm fluorescent industrial lights or for initial installation in commercial buildings, warehouses and working areas. Improved light quality and uniformity allows optimal working conditions.**

*Policarbonate body*  
*L70 >60.000 hrs*  
*RA: >85*  
*IP65 protection*  
*230 VAC Class II*  
*Weight: 2,5 kg*  
*Available 4500K*



**DETAS SpA** - Dleds division  
 Via Treponti, 29 - 25086 Rezzato (BS) ITALY  
 Tel. +39 030 2594120 - Fax +39 030 2792864  
**www.dleds.com** - info@dleds.com

An ISO 9001:2008 certified company  
 RAEE IT8020000001378  
 Con riserva di modifiche S.E.&O. / Subject to change E.&O.E.

# Kesu

Plafoniera a LED 120cm per sostituzione  
fluorescenti  
*Low bay industrial LED light*

**230 VAC**



# Janus

Modelli / Models	
Type	Power [W]
JANUS 55 230VAC	<b>55</b>
JANUS 100 230VAC	<b>100</b>
JANUS 150 230VAC	<b>150</b>

## Ottiche disponibili / Available optics

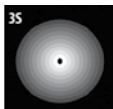

**Plafoniera a LED ideale per applicazioni a soffitto o a sospensione in ambienti dove il design è importante e le potenze richieste sono elevate.**

Corpo in alluminio con lente in policarbonato  
Finitura nera o grigia  
L70 > 60.000 ore  
Protezione IP54  
230VAC classe I  
Peso : 4,8 Kg  
Driver esterno  
Versione dimmerabile su richiesta  
Disponibile 4000K, 5000K

***Suitable for high&low bay industrial installations. Very good price/performance ratio. Very attractive appearance.***

*Aluminum body with polycarbonate diffuser  
Black or silver finishing  
L70 >60.000 hrs  
IP54 protection  
230 VAC Class I  
Weight: 4,8 kg  
External driver  
Dimmable versions available on request  
Available 3000K, 4100K, 5500K*

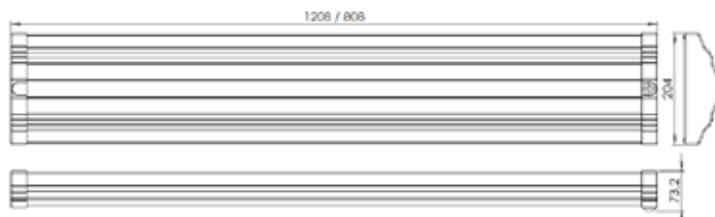

**DETAS SpA** - Dleds division  
Via Treponti, 29 - 25086 Rezzato (BS) ITALY  
Tel. +39 030 2594120 - Fax +39 030 2792864  
**www.dleds.com** - info@dleds.com

An ISO 9001:2008 certified company  
RAEE IT8020000001378  
Con riserva di modifiche S.E.&O. / Subject to change E.&O.E.



# Janus

Plafoniera a LED per applicazioni  
all'interno.  
*Indoor LED light*

**230 VAC**



# Pad

Modelli / Models				Ottiche disponibili Available optics			
nr. LED	Type	Current [mA]	Power [W]	nr. LED	Type	Current [mA]	Power [W]
40	R	550	<b>68</b>	80	R	550	<b>135</b>
40	R	700	<b>85</b>	80	R	700	<b>175</b>
60	R	550	<b>100</b>	100	R	550	<b>173</b>
60	R	700	<b>125</b>	100	R	700	<b>215</b>

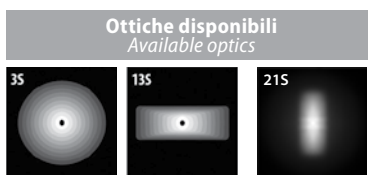

**Progettato per aggiornare, con tecnologia LED, l'illuminazione di impianti industriali, edifici commerciali e magazzini.**

Corpo in alluminio pressofuso  
Vetro temprato 5 mm  
L70 >70.000 ore  
Protezione IP54  
230 VAC Classe II, disponibile anche Classe I  
Certificato rischio esente sicurezza fotobiologica  
Peso 12 kg  
Disponibile 3000K, 4100K, 5500K

**High bay LED light for replacing existing HID/HPS lights or for initial installation in commercial buildings, warehouses and working areas. Improved light quality allows for optimal working conditions.**

*Aluminum die cast body  
Tempered glass 5 mm  
L70 >70.000 hrs  
IP54 protection  
230 VAC Class II, available also Class I  
Certified photobiological safety risk exempt  
Weight 12 kg  
Available 3000K, 4100K, 5500K*

**Dimmer e controllo remoto wireless su richiesta.**

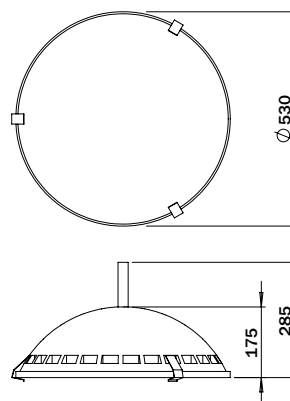

**DETAS SpA** - Dleds division  
Via Tre Ponti, 29 - 25086 Rezzato (BS) ITALY  
Tel. +39 030 2594120 - Fax +39 030 2792864  
**www.dleds.com** - info@dleds.com

An ISO 9001:2008 certified company  
RAEE IT80200000001378  
Con riserva di modifiche S.E.&O. / Subject to change E.&O.E.



# Pad

Corpo illuminante a LED per capannoni  
*High bay LED light*

**230 VAC**

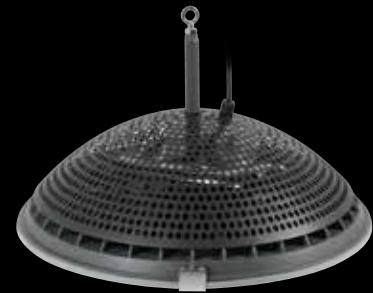

# Gong & Zak

Modelli / Models											
nr. LED	Type	Current [mA]	Power [W]	nr. LED	Type	Current [mA]	Power [W]	nr. LED	Type	Current [mA]	Power [W]
15	R	700	<b>33</b>	30	R	550	<b>53</b>	40	R	425	<b>70</b>



## Per aggiornamento, con tecnologia LED, di pensiline e garage.

Corpo in alluminio pressofuso  
 Lente in Lexan (PC)  
 L70 >100.000 ore  
 Protezione IP54  
 230 VAC Classe II  
 Disponibile anche Classe I  
 Peso: 4 kg Gong - 4.8 kg Zak  
 Disponibile 3000K, 4100K, 5500K

## LED fixture used for garages, low bay installations, warehouses and canopies.

Aluminum die cast body  
 Lexan (PC) lens  
 L70 >100.000 hrs  
 IP54 protection  
 230 VAC Class II  
 Available also Class I  
 Available 3000K, 4100K, 5500K  
 Weight: 4 kg Gong - 4.8 kg Zak

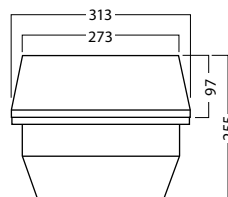
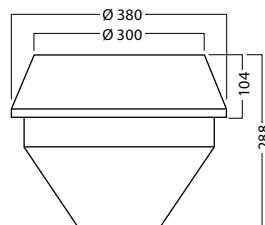

**DETAS SpA** - Dleds division  
 Via Treponti, 29 - 25086 Rezzato (BS) ITALY  
 Tel. +39 030 2594120 - Fax +39 030 2792864  
[www.dleds.com](http://www.dleds.com) - [info@dleds.com](mailto:info@dleds.com)

An ISO 9001:2008 certified company  
 RAEE IT80200000001378  
 Con riserva di modifiche S.E.&O. / Subject to change E.&O.E.

# Gong & Zak

Corpi illuminanti a LED  
per pensiline e garage  
*LED fixture for garages and canopies*

**230 VAC**



**GONG**



**ZAK**



# Trilogy Bust

Applicazioni:

- Fermate bus
- Pensiline
- Cancelli
- Giardini
- Patii
- Chioschi
- Cartelli pubblicitari ecc.

Ideal for:

- **Bus stops**
- **Shelters**
- **Canopies**
- **Gates**
- **Gardens**
- **Patios**
- **Kiosks**
- **Advertising signs** etc.

Modello / Model
Photovoltaic Module Power[W]
<b>10</b>

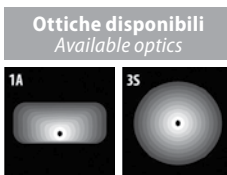

**È la scelta più semplice ed economica per illuminare con estrema efficacia punti normalmente non raggiungibili dalla rete elettrica.**

Contenitore in alluminio  
Vetro temprato 4 mm  
L70 >100.000 ore  
Protezione IP65  
Peso 1.5 kg Trilogy; 8.2 kit PV  
Disponibile 3000K, 4100K, 5500K

**The easiest and less expensive way to properly light places not reached by the power grid.**

Aluminum body  
Tempered glass 4 mm  
L70 >100.000 hrs  
IP65 protection  
Available 3000K, 4100K, 5500K  
Weight 1.5 kg Trilogy; 8.2 kg kit PV

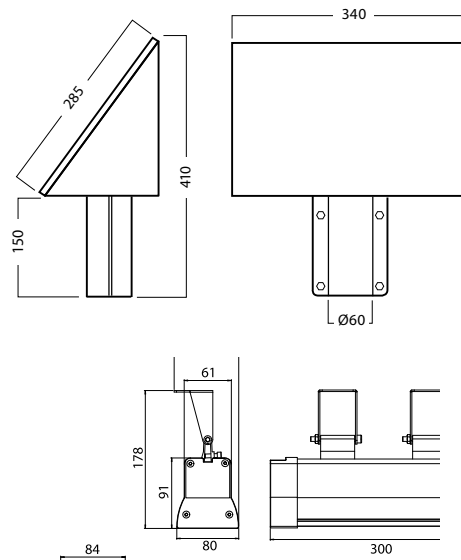

**DETAS SpA** - Dleds division  
Via Treponti, 29 - 25086 Rezzato (BS) ITALY  
Tel. +39 030 2594120 - Fax +39 030 2792864  
[www.dleds.com](http://www.dleds.com) - [info@dleds.com](mailto:info@dleds.com)

An ISO 9001:2008 certified company  
RAEE IT80200000001378  
Con riserva di modifiche S.E.&O. / Subject to change E.&O.E.

# Trilogy Bust

Kit fotovoltaico Trilogy  
*Trilogy photovoltaic kit*

**12 VDC**

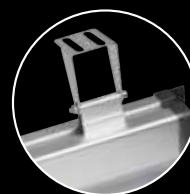

[www.dleds.com](http://www.dleds.com)



DLEDS is a division of DETAS SpA  
Via Treponti, 29 - 25086 Rezzato (BS) ITALY  
Tel. +39 030 2594120 - Fax +39 030 2792864  
[info@dleds.com](mailto:info@dleds.com)

An ISO9001 certified company

Per maggiori informazioni consultate il nostro sito  
[www.dleds.com](http://www.dleds.com)  
Schede tecniche e file fotometrici disponibili su  
richiesta.

*For more information please visit  
[www.dleds.com](http://www.dleds.com)  
Technical sheets and photometric files are available on  
request.*

